



fives

LANDIS LT2HE

CNC orbital grinder

Date: 11/10/20

Prepared by: Caitlin Barnhart

CNC orbital grinder

Grinding of crankpins & journals on large crankshafts using single or twin wheelheads

- Landis system CNC control
- Capacity: up to 1400mm Twin Wheelhead up to 3000mm single Wheelhead
- CNC hydrostatic wheelhead feed
- CNC hydrostatic cross slides traverse
- Hydrostatic wheel spindles
- CBN grinding wheels
- CNC wheel dressing
- Integral wheel spindle drives
- Variable speed workdrive
- Work supported by centres or work fixtures
- Fixed rigid work axis
- Brushless servos on all axes
- Linear motor and absolute encoder technology on X and Z axes
- Automatic wheel balancing
- Automatic in-process gauging
- Flexible table tooling with rack & pinion adjustment



User List – Single & Twin Wheelhead

ALBION AUTOMOTIVE

LEYLAND (UK) - 2

ASHOK LEYLAND

ENNORE (INDIA) - 4

AVADI

CHENNAI (INDIA) - 1

BHAGAT FORGE LTD.

LUDHIANA (INDIA) - 1

BOEHRINGER / KAMAZ

(RUSSIA) - 2

COFMOW

PATIALA (INDIA) - 1

CUMMINS INDIA LTD.

PUNE (INDIA) - 2

DAIMLER A.G.

MANNHEIM (GERMANY) - 7

DONG FENG MOTOR CORP

SHIYAN (CHINA) - 5

ENGINE FACTORY

CHENNAI (INDIA) - 2

ENGINE POWER COMPONENTS

EIBAR (SPAIN) - 1

F.A.W. 1st Engine Works

CHANGCHUN (CHINA) - 10

F.F.G. EUROPE & AMERICAS

NABEREZHNYE CHELNY (FRANCE) - 1

FIAT

BOURBON LANCY (FRANCE) - 2

FIVES LANDIS LTD.

CROSS HILLS (UK) - 1

FORD OTOSAN

ESKISEHIR (TURKEY) - 2

FUDA

GUILIN (CHINA) - 25

WUHAN - 1

XIANGFAN - 2

XIANGYANG (CHINA) - 6

GUANGXI YUCHAI

YULING (CHINA) - 1

HAPPY FORGINGS

LUDHIANA (INDIA) - 9

JINAN DIESEL

JINAN (CHINA) - 1

KIRLOSKAR OIL

PUNE (INDIA) - 1

LIAONING 518

LIAONING (CHINA) - 3

LIAONING SHUNXING HEAVY DIESEL

DENGTA LIAOLING (CHINA) - 2

LING YUAN HONG FA

LING YUAN (CHINA) - 1

LOMBARDINI

REGGIO EMILIA (ITALY) - 1

LOUYANG 1st TRACTOR Co.

LOUYANG (CHINA) - 2

NETALKER POWER TRANSMISSION

BELGAVI (INDIA) - 1

SCANIA

SODERTALJE (SWEDEN) - 2

SINOTRUK JINAN FUQIANG POWER Co.

JINAN (CHINA) - 1

TATA MOTORS

JAMSHEDPUR (INDIA) - 2

TATA MOTORS

PUNE (INDIA) - 2

TIANRUN CRANKSHAFT Co.

WENDENG (CHINA) - 3

TOTAL 110 MACHINES

Camshaft User List

ENGINE POWER COMPONENTS

EIBAR (SPAIN) - 1

BHAGAT FORGE LTD.

LUDHIANA (INDIA) - 1

CUMMINS INDIA LTD.

PUNE (INDIA) - 2

COFMOW

PATIALA (INDIA) - 1

JINAN DIESEL

JINAN (CHINA) - 1

KIRLOSKAR OIL

PUNE (INDIA) - 1

TOTAL 7 MACHINES

Crankshaft User List

ALBION AUTOMOTIVE

LEYLAND (UK) - 2

ASHOK LEYLAND

ENNORE (INDIA) - 4

AVADI

CHENNAI (INDIA) - 1

BOEHRINGER / KAMAZ

(RUSSIA) - 2

COFMOW

PATIALA (INDIA) - 1

DAIMLER A.G.

MANNHEIM (GERMANY) - 7

DONG FENG MOTOR CORP

SHIYAN (CHINA) - 5

ENGINE FACTORY

CHENNAI (INDIA) - 2

F.A.W. 1st Engine Works

CHANGCHUN (CHINA) - 10

F.F.G. EUROPE & AMERICAS

NABEREZHNYE CHELNY (FRANCE) - 1

FIAT

BOURBON LANCY (FRANCE) - 2

FIVES LANDIS LTD.

CROSS HILLS (UK) - 1

FORD OTOSAN

ESKISEHIR (TURKEY) - 2

FUDA

GUILIN (CHINA) - 25

WUHAN - 1

XIANGFAN - 2

XIANGYANG (CHINA) - 6

GUANGXI YUCHAI

YULING (CHINA) - 1

HAPPY FORGINGS

LUDHIANA (INDIA) - 9

KIRLOSKAR OIL

PUNE (INDIA) - 1

LIAONING 518

LIAONING (CHINA) - 3

LIAONING SHUNXING HEAVY DIESEL

DENGTA LIAOLING (CHINA) - 2

LING YUAN HONG FA

LING YUAN (CHINA) - 1

LOMBARDINI

REGGIO EMILIA (ITALY) - 1

LOUYANG 1st TRACTOR Co.

LOUYANG (CHINA) - 2

NETALKER POWER TRANSMISSION

BELGAVI (INDIA) - 1

SCANIA

SODERTALJE (SWEDEN) - 2

SINOTRUK JINAN FUQIANG POWER Co.

JINAN (CHINA) - 1

TATA MOTORS

JAMSHEDPUR (INDIA) - 2

TATA MOTORS

PUNE (INDIA) - 2

TIANRUN CRANKSHAFT Co.

WENDENG (CHINA) - 3

TOTAL 103 MACHINES

Tooling Table

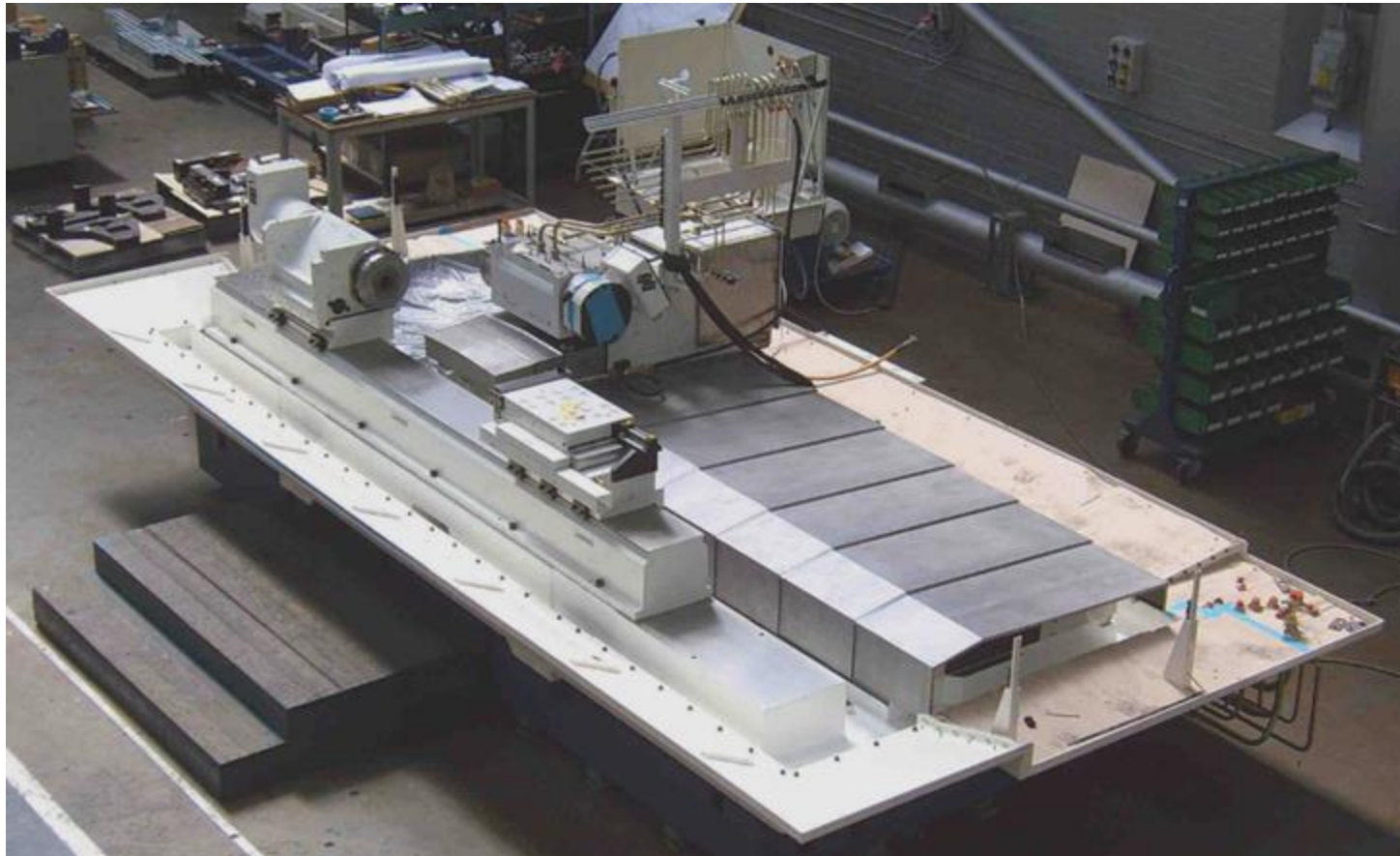

Wheelhead Slide (Z-Axis / Z1 Axis)

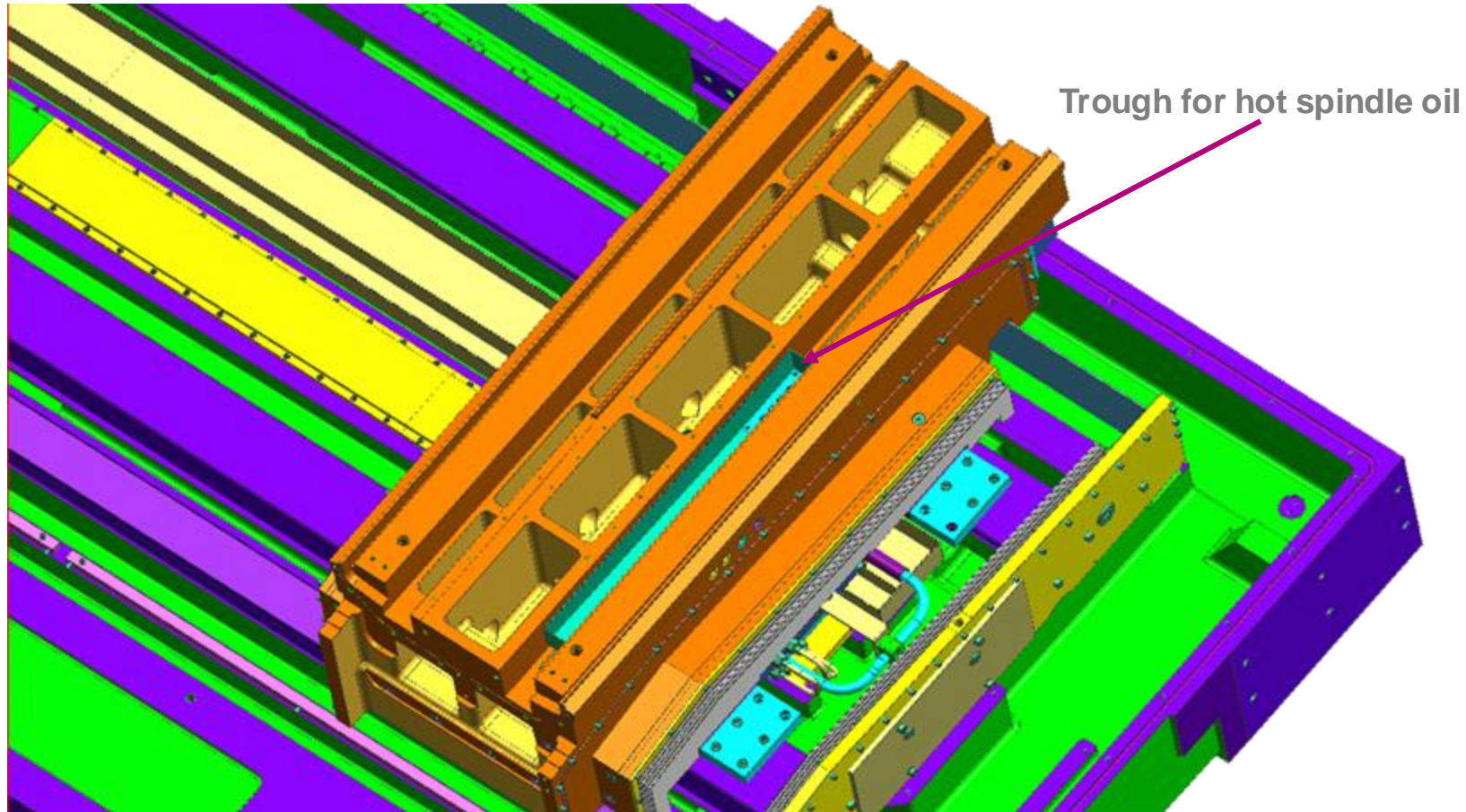

Wheelhead Slide (X-Axis / X1 Axis)

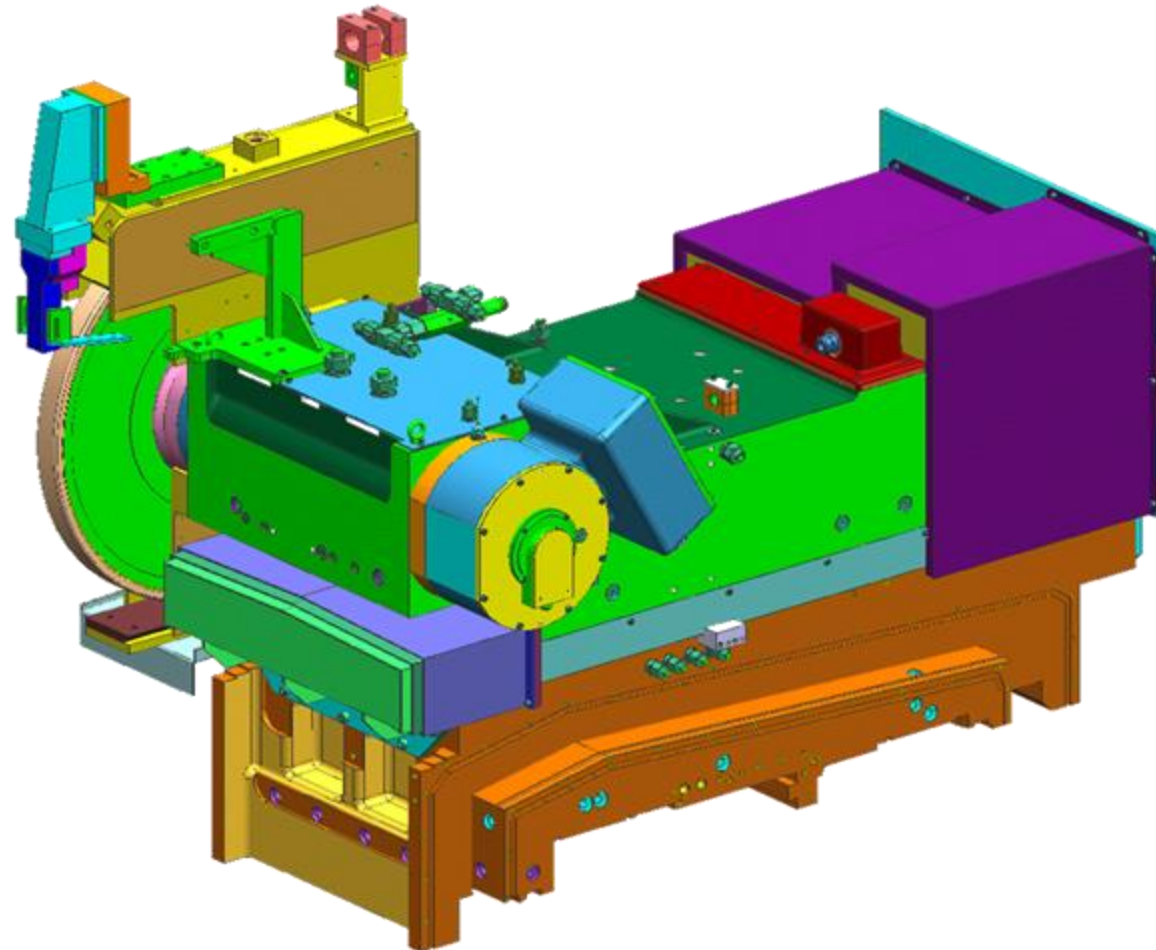

Wheel Guard

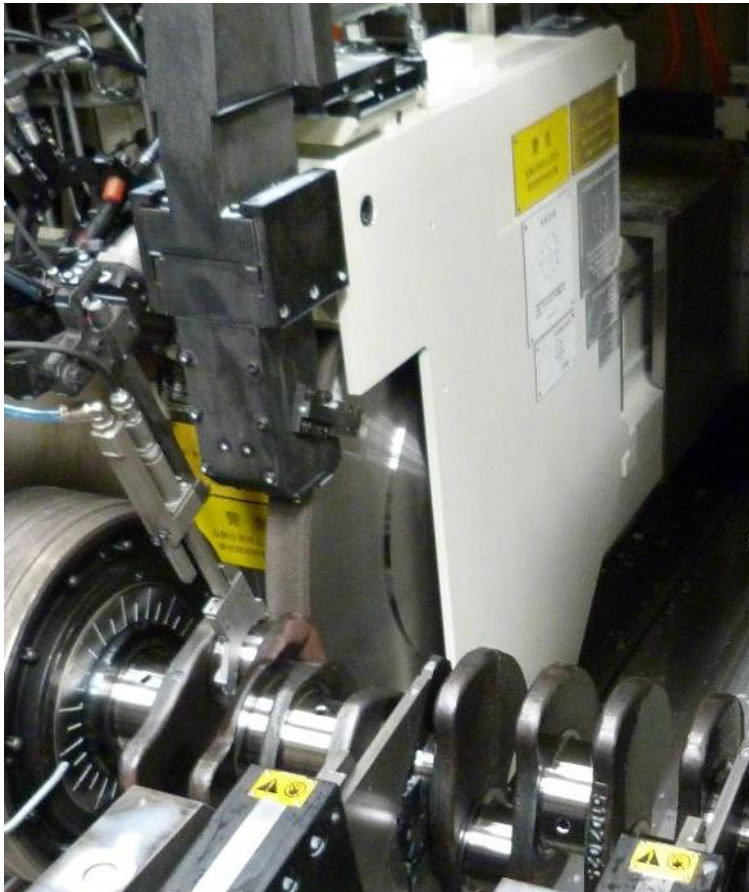

Wheel Spindle (S-Axis / S1-Axis)

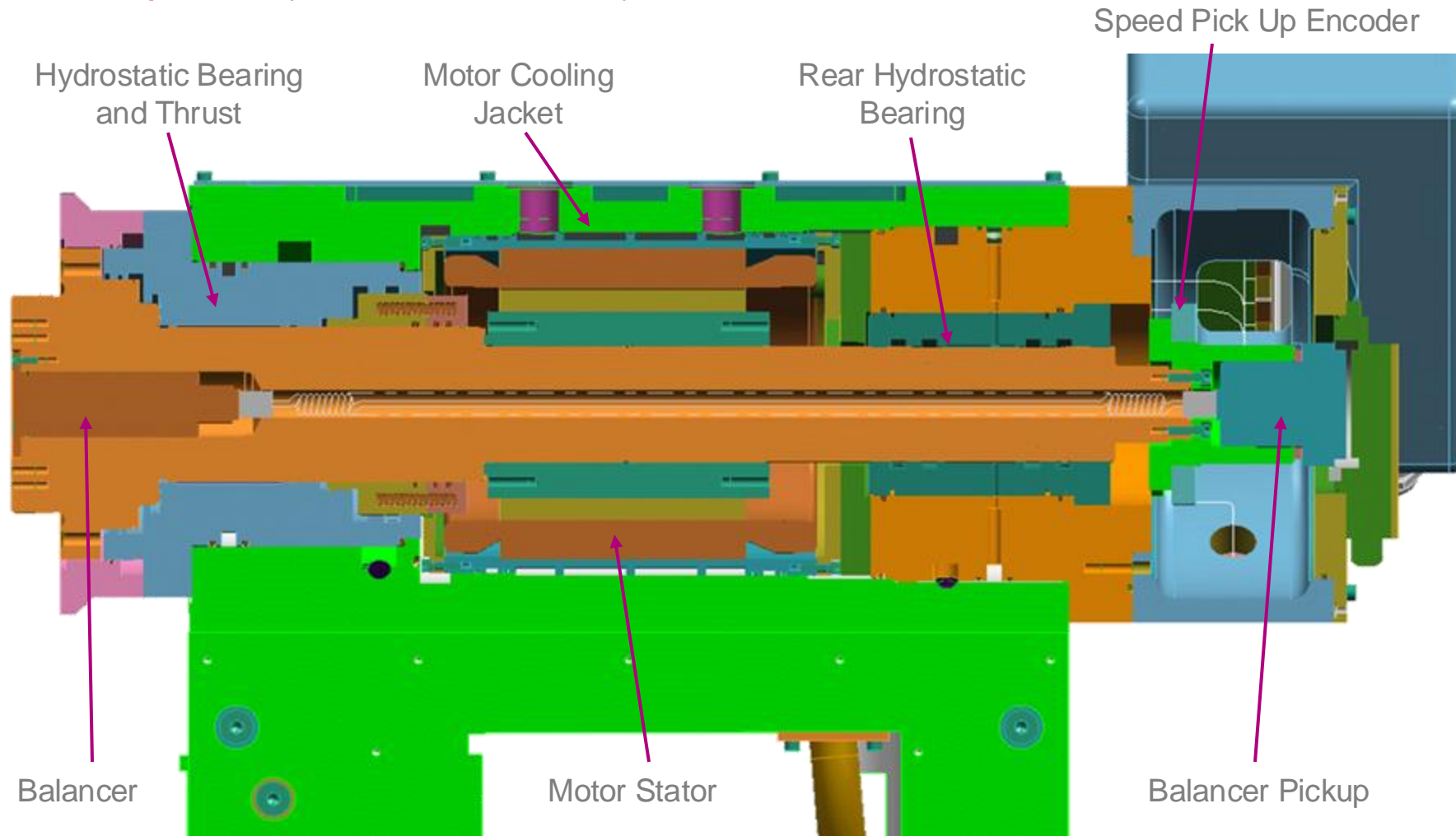

Wheel Dressing Unit

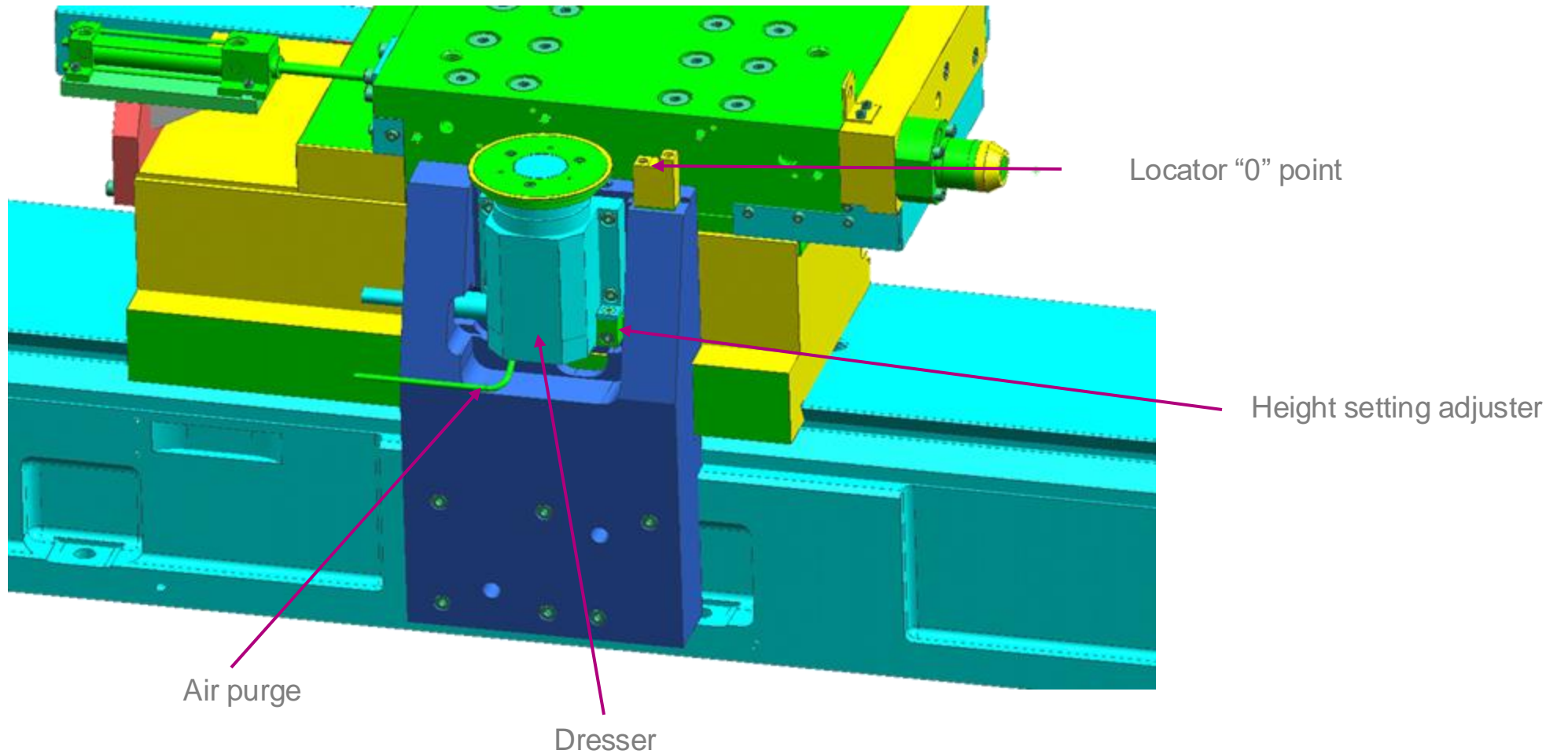

Headstock (C-Axis)

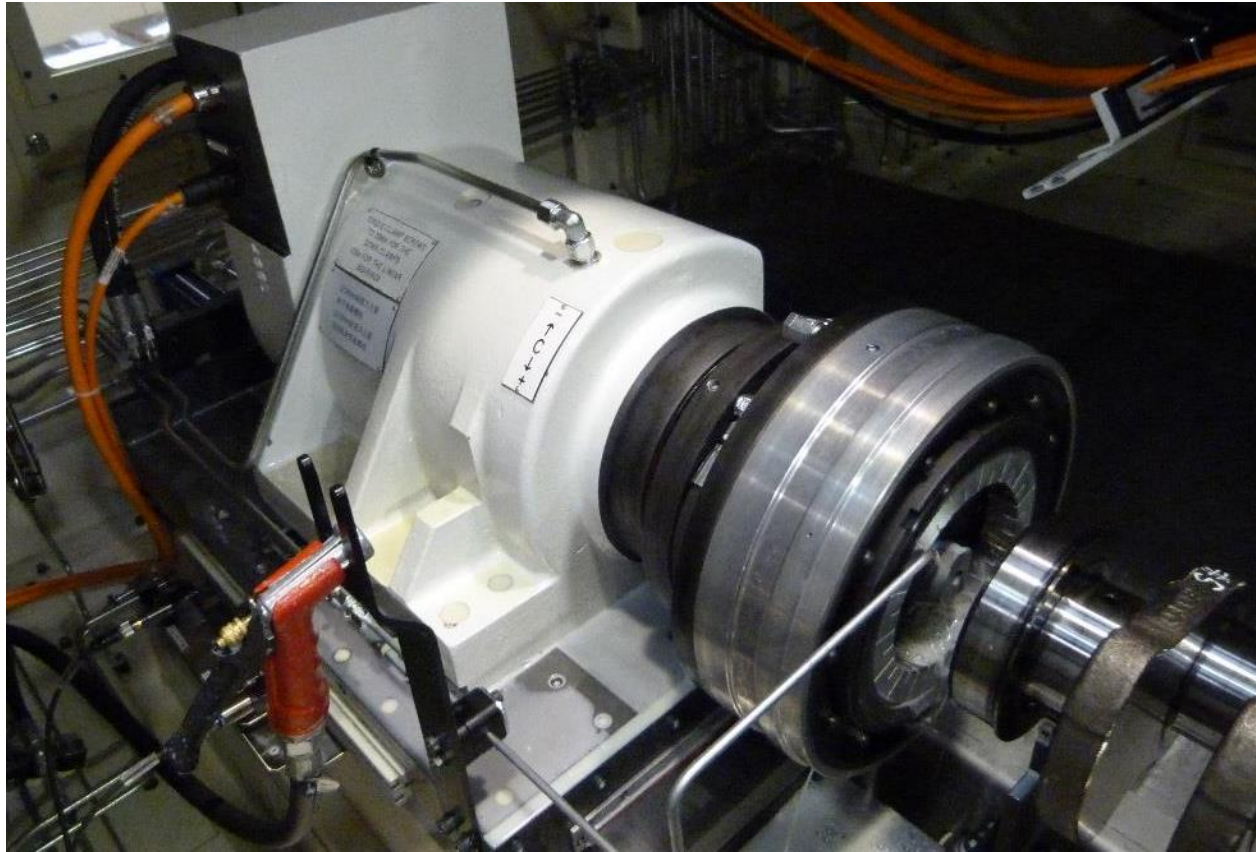

Footstock

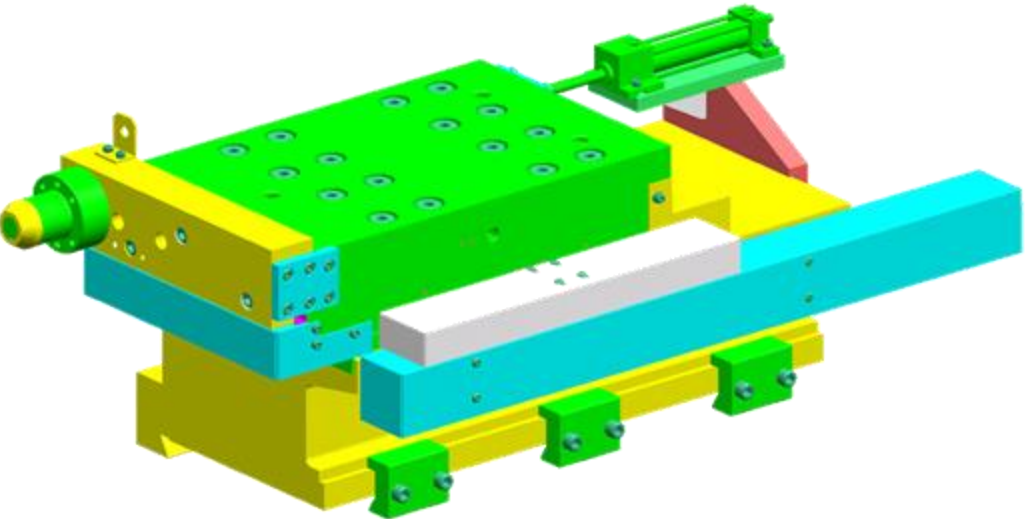
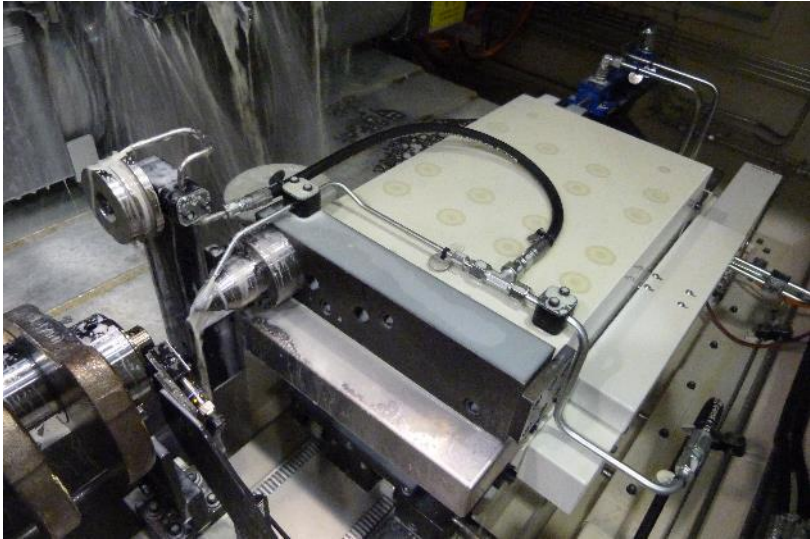



Automatic Sizing Gauge

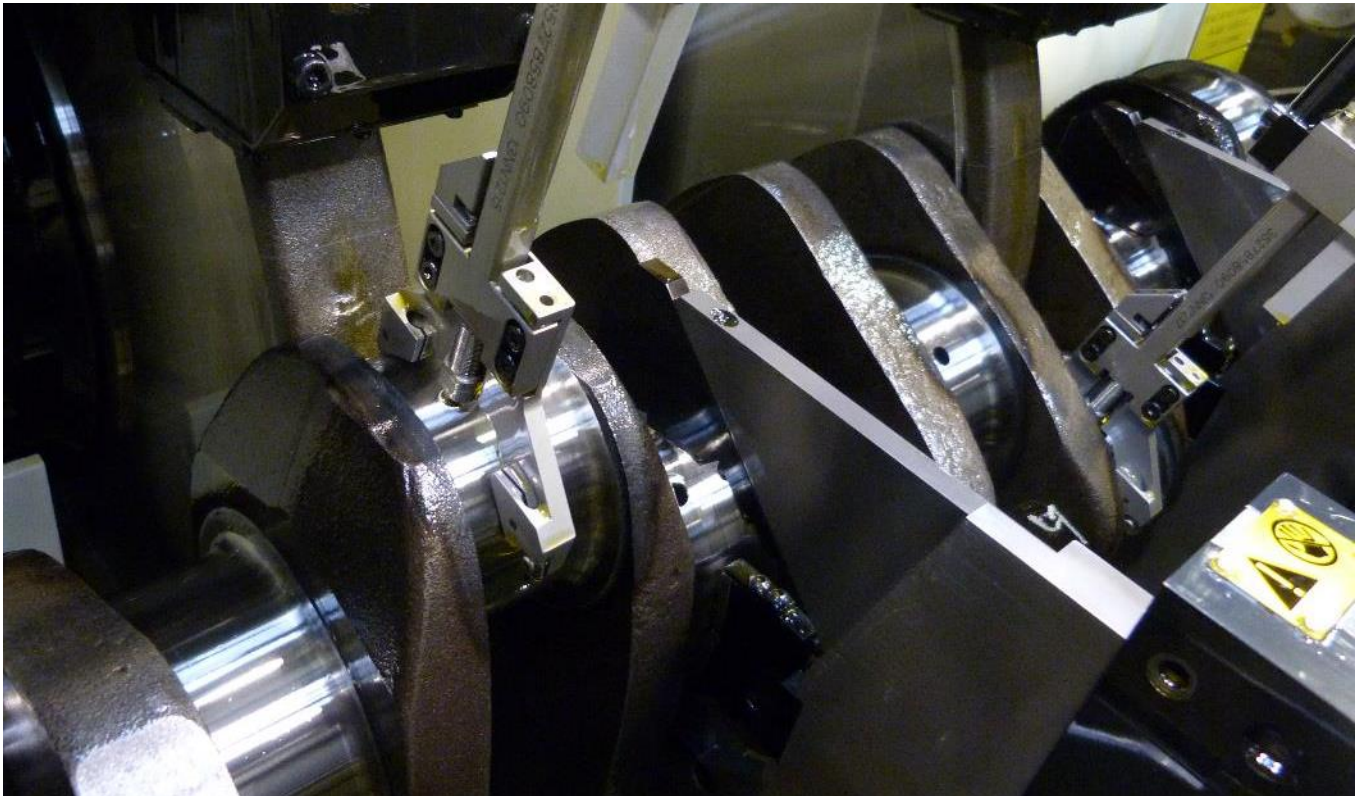

Radial Location Probe

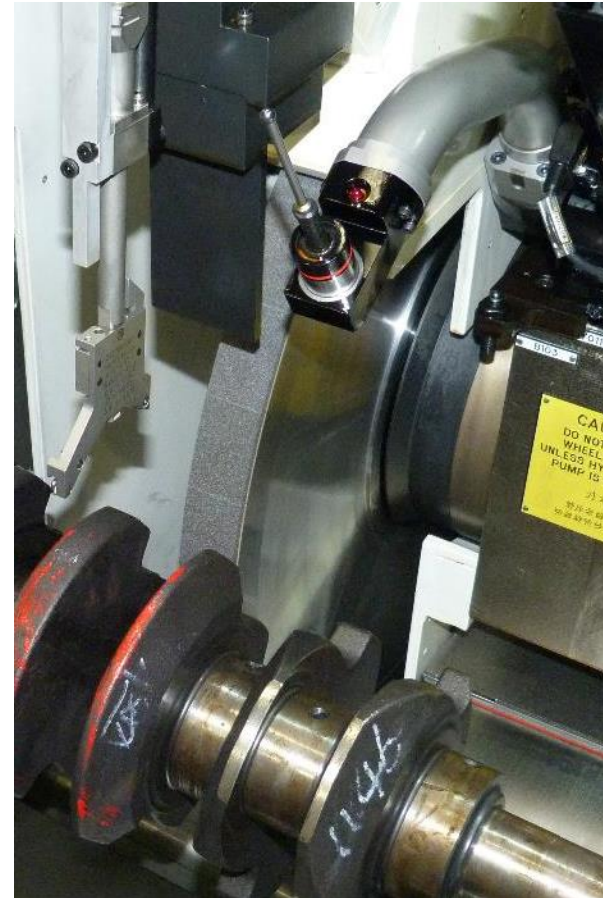
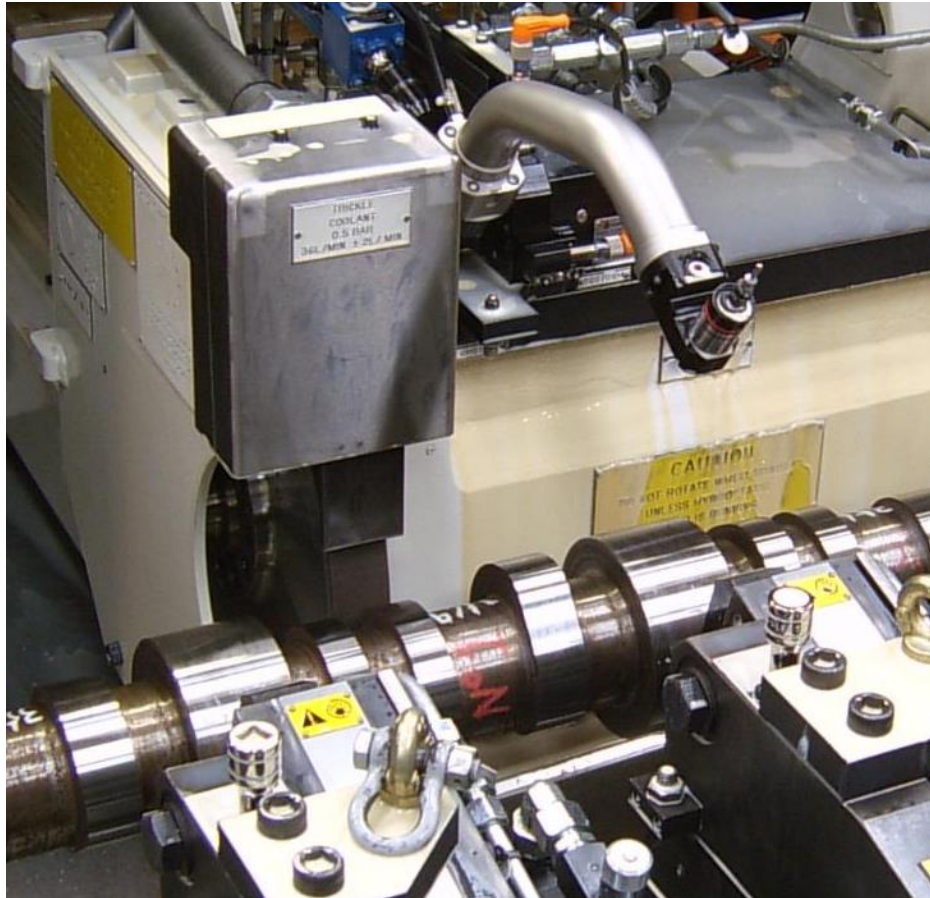

Finish grinding on mains & pins, including sidewalls and radii

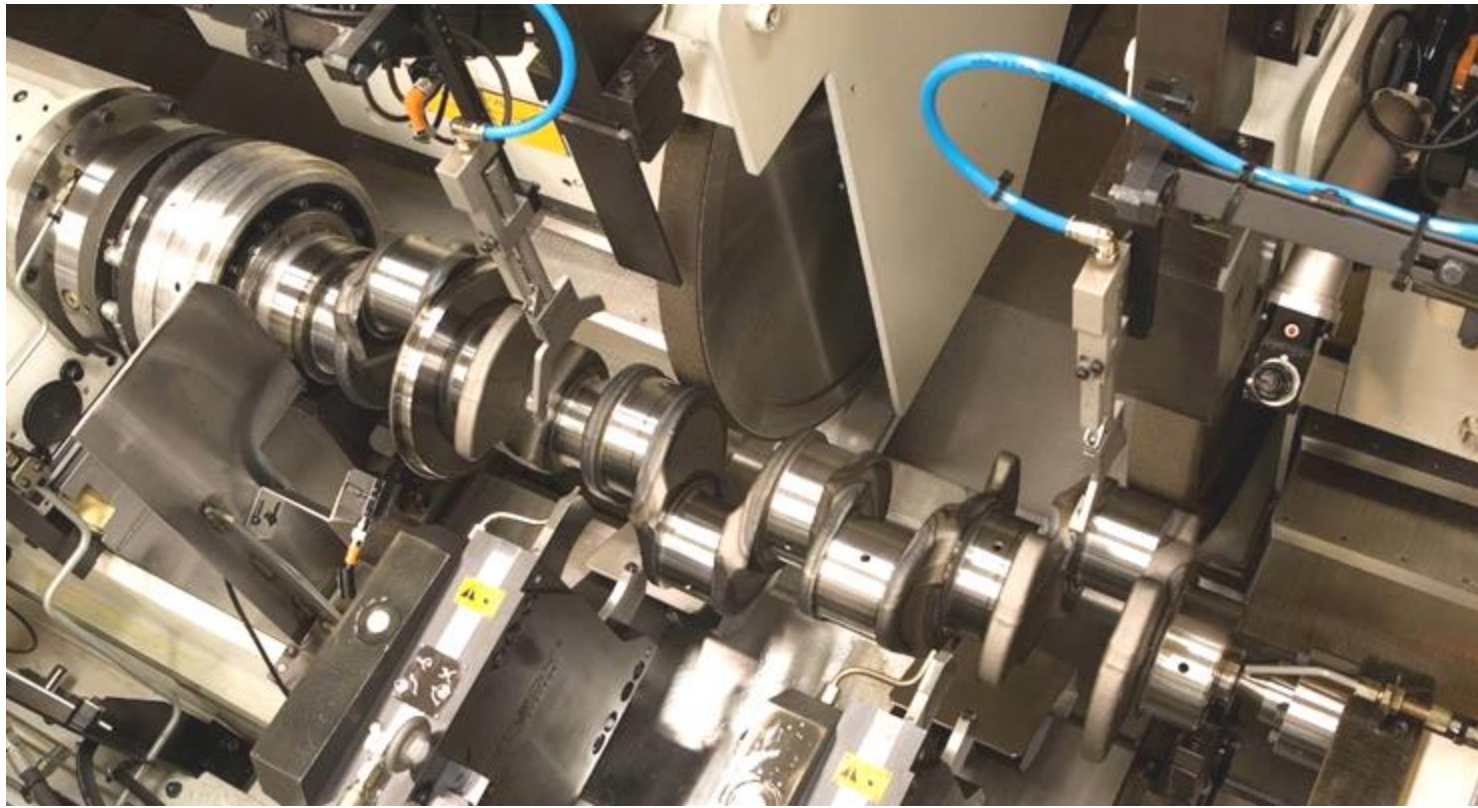

Finish grinding intake, exhaust cam lobes and injectors

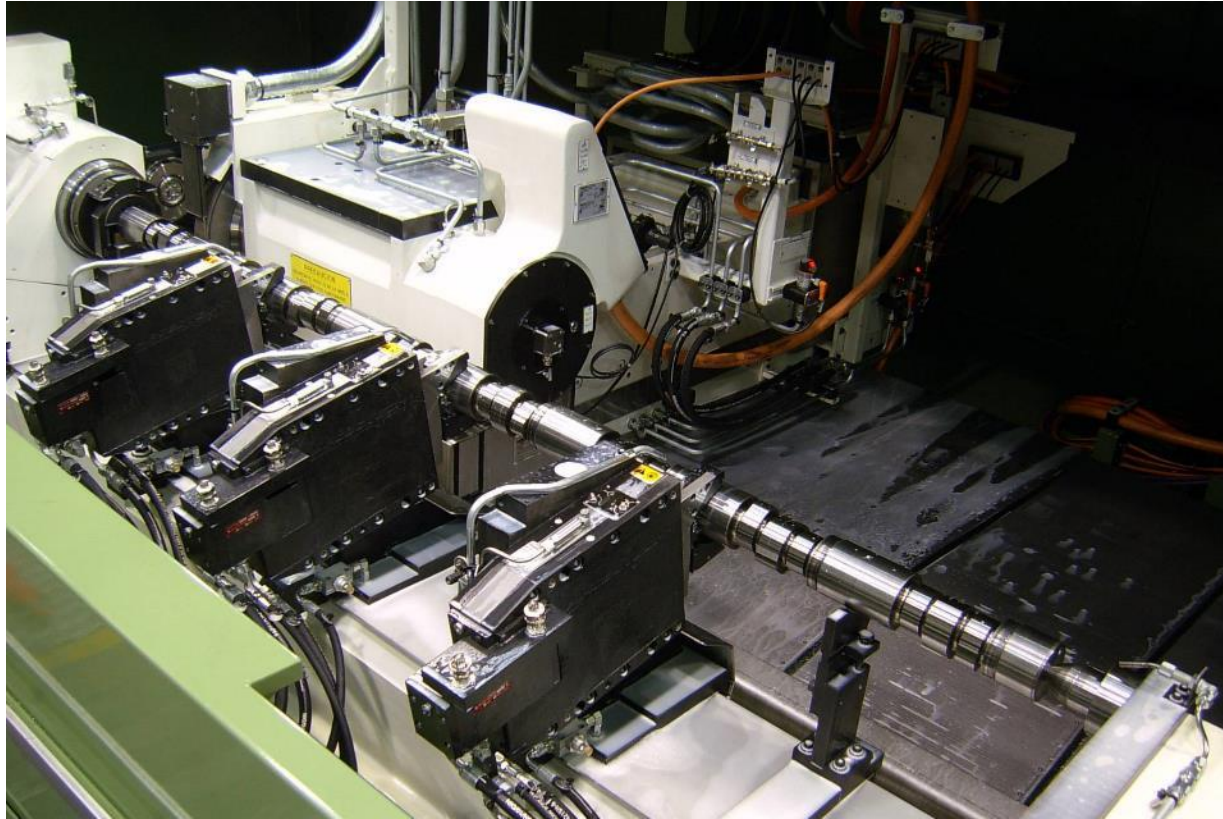

Semi finish and finish grind cam lobes on various shafts

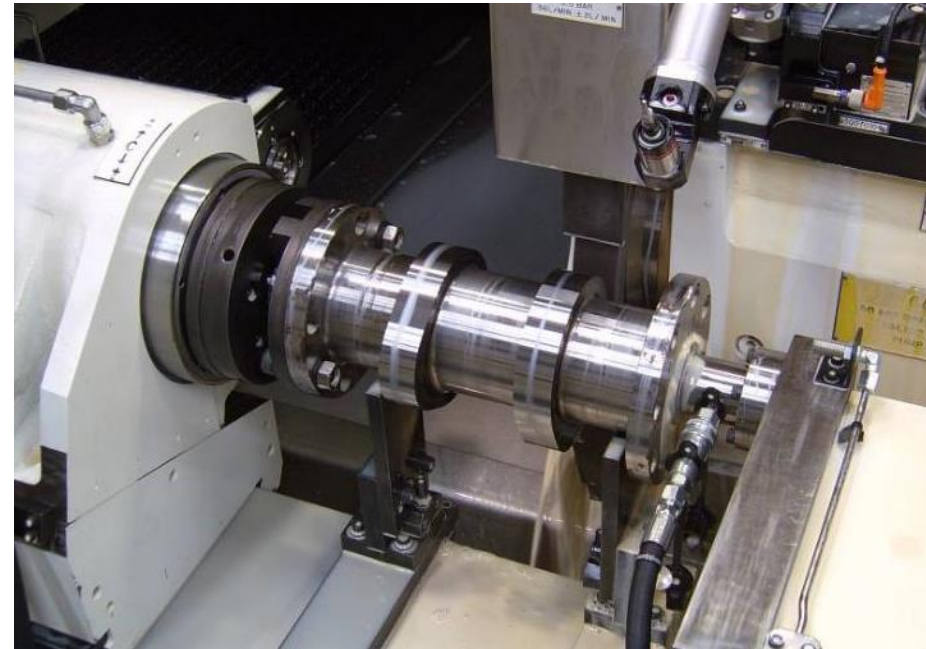
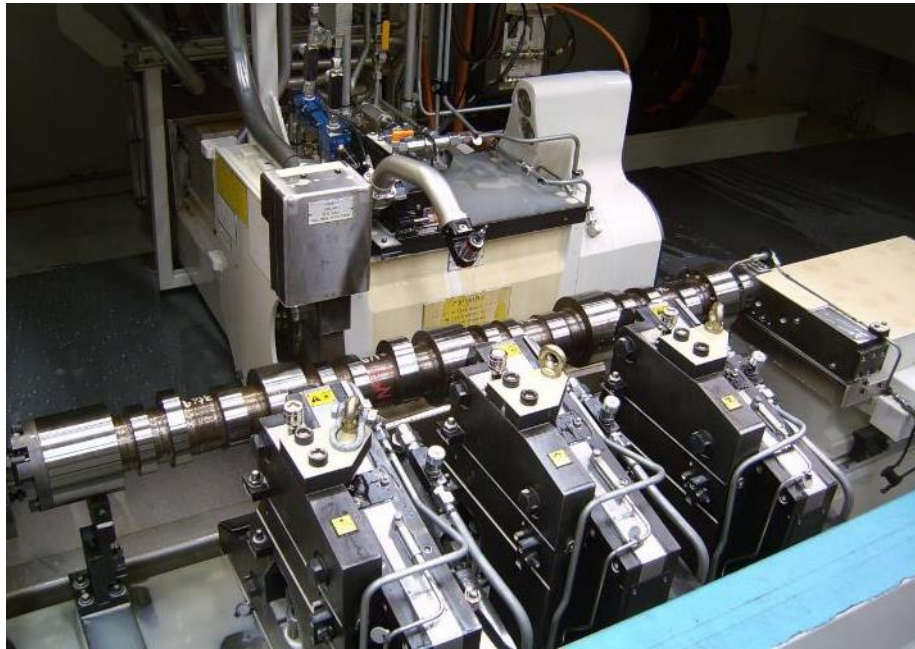

Finish grind mains & pins including sidewalls & radii
Finish grinding lobes & journals

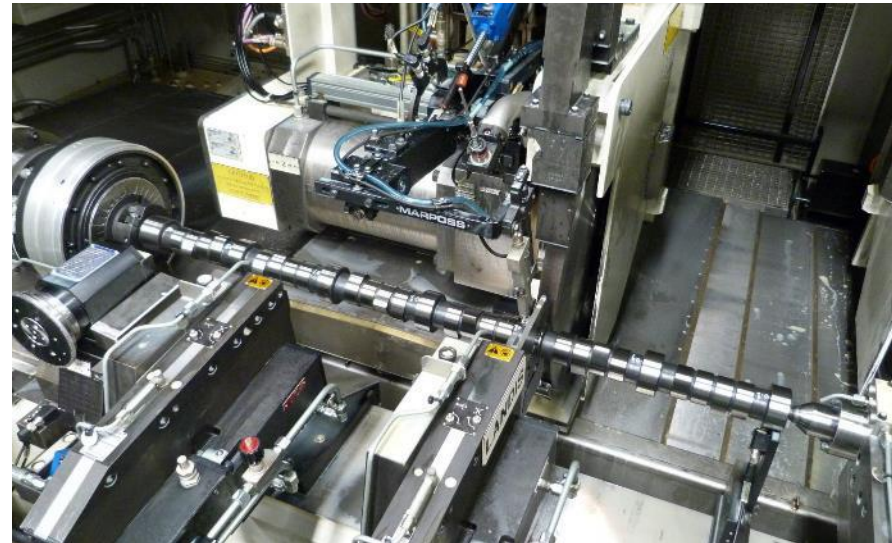
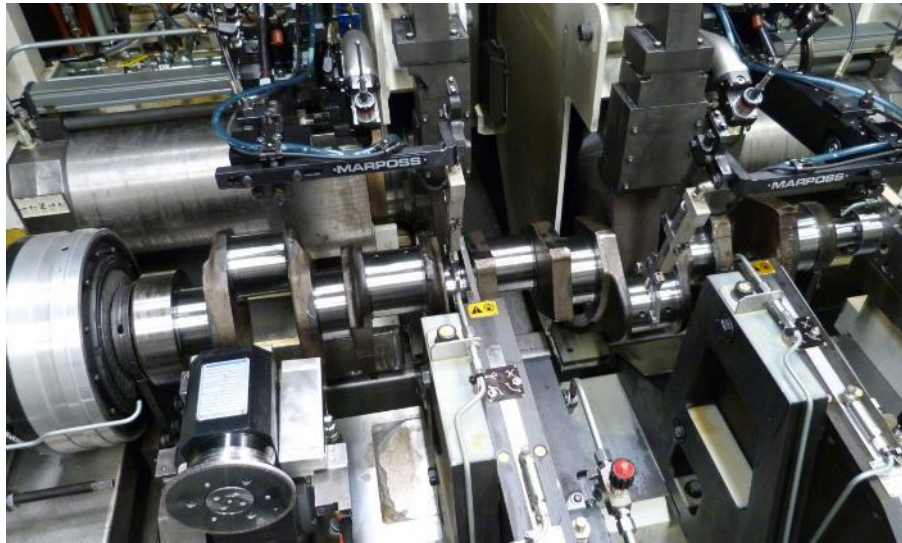

Specifications

	Landis LT2He Single Wheelhead *2 Spindle Swivel Optional	Landis LT2He Twin Wheelhead
Grinding capacity		
Max. component swing	550 mm (21.7")	550 mm (21.7")
Max. grinding length	3,000 mm (118")	1,400 mm (118")
Max. workpiece weight	500 kg (1,102 lb)	500 kg (1,102 lb)
Wheelhead		
Wheel type	CBN	
Max. wheel Ø	120 / 400 / 675 mm options (4.7" / 15.8" / 26.6")	675 mm (26.6")
Max. wheel width	80 mm (3")	80 mm (3")
Max. wheel surface speed	150 m/sec (492 ft/sec)	150 m/sec (492 ft/sec)
Max. spindle power	25 / 65 / 95 kW options	95 kW
B-axis swivel range	*Optional 230° infinitely	N/A

Specifications

	Landis LT2He Twin Wheelhead *2 Spindle Swivel Optional	Landis LT2He Twin Wheelhead
Workhead & footstock		
Max workhead speed	600 rpm	300 rpm
Workhead drive power	13 kW	20 kW
Max. workhead motor torque	160 Nm	280 Nm
Footstock stroke	160 mm (6.3")	
Axes		
Linear guide ways	Hydrostatics	Hydrostatics
Grinding spindle	Hydrostatics	
Drive	Linear motors	
Dimensions		
Dimensions (W x D x H)	7,552 x 5,464 x 2,800 mm (24.8" x 18" x 9.2")	
Machine weight	26,000 kg (57,320 lbs)	29,000 kg (63,934 lb)